

**THROUGH FRAME  
INSTALLATION**

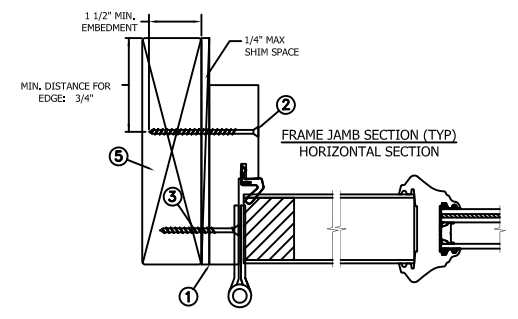
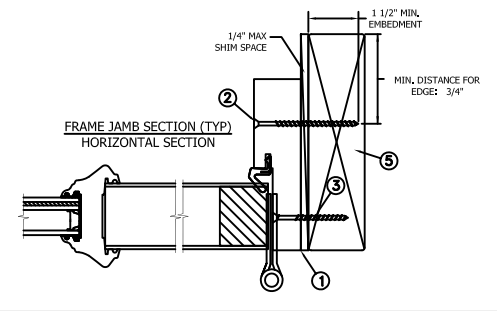

Max Frame	DP Rating	Impact
74" x 96 7/8"	+50/-50	YES

**Installed Fastener Schedule:**

1. Seal flange/frame to substrate.
2. Use #12 PH or greater fasteners through frame with sufficient length to penetrate a minimum of 1 1/2" into the wood framing. For 2X wood frame substrate (min. S.G. = 0.42).
3. Install corrosion resistant 1-#8 X 2" screws through each hinge into rough opening.
4. Install corrosion resistant 2-#8 X 2" screws through each strike plate into rough opening.
5. Host structure (wood buck, stud framing and opening) to be designed and anchored to properly transfer all loads to the structure. The host structure is the responsibility of the architect or engineer of record for the project of installation.

**General Notes:**

1. The product shown herein is designed, tested and manufactured to comply with the wind load criteria of the adopted International Building Code (IBC), the International Residential Code (IRC), the Florida Building Code (FBC) excluding HVHZ and the industry standard requirement for the stated conditions.
2. Buck, framing and masonry by others and is responsibility of architect or engineer of record.
3. All glazing shall conform to ASTM E1300.
4. At minimum, glazing shall be 3.0mm tempered - 14.1mm airspace - 3.0mm annealed - 2.3mm PVB Interlayer by Dupont - 3.0mm annealed insulating glass.

This schedule addresses only the fasteners required to anchor the window to achieve the rated design pressure up to the size limitations noted. It is not intended as a guide to the installation process and does not address the sealing consideration that may arise in different wall conditions. For the complete installation procedure, see the instructions packaged with the door or go to [www.jeld-wen.com](http://www.jeld-wen.com).

**DISCLAIMER:**

This drawing and its contents are confidential and are not to be reproduced or copied in whole or in part or used or disclosed to others except as authorized by JELD-WEN Inc.

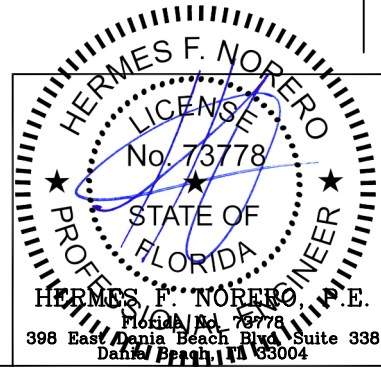

PROJECT ENGINEER: ---	DATE: 11/02/2017	<b>JELD-WEN</b>	3737 Lakeport Blvd Klamath Falls, OR. 97601 Phone: (800) 535-3936		
DRAWN BY: D. Vezo	SCALE: NTS				
CHECKED BY: J. Hawkins	TITLE: Architectural Fiberglass Impact Opaque 2 Panel Outswing Door				
APPROVED BY: D. Vezo					
PART/PROJECT No.:	D014773				
IDENTIFIER No. TEL 01681715	PLANT NAME AND LOCATION: ----	CAD DWG. No.:	REV:	SHEET	

3" FROM CENTER      4" FROM CENTER      6" MAX. FROM CORNERS

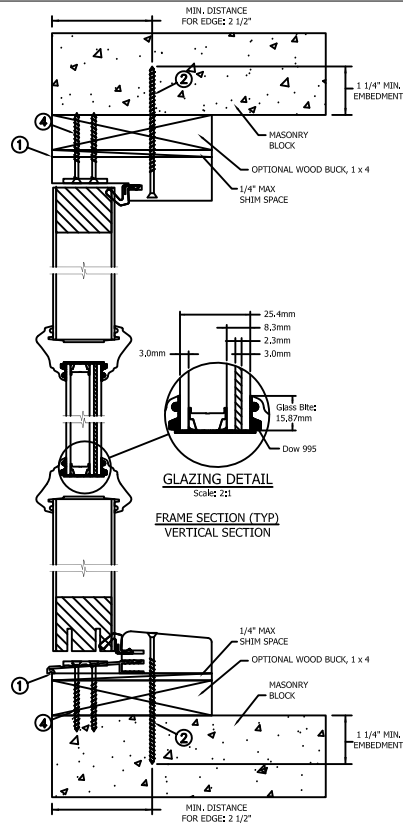
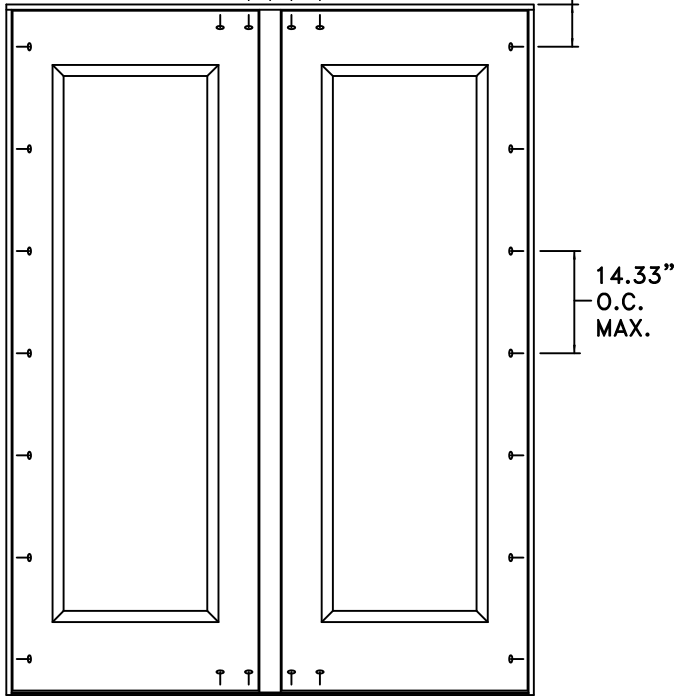

**THROUGH FRAME INSTALLATION**

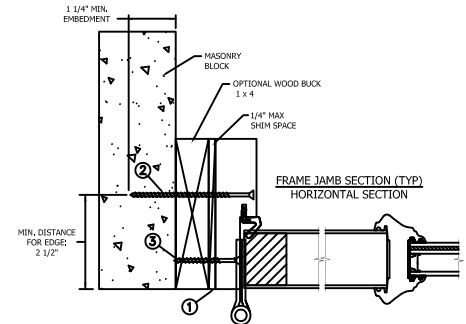
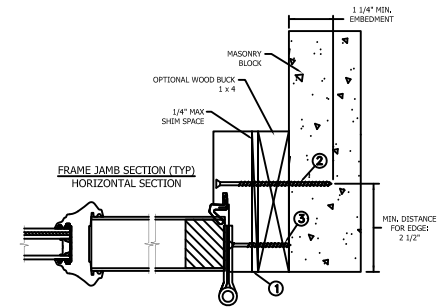

Max Frame	DP Rating	Impact
74" x 96 7/8"	+50/-50	YES

**Installed Fastener Schedule:**

1. Seal flange/frame to substrate.
2. Use 3/16" Tapcon or equivalent fasteners through frame with sufficient length to penetrate a minimum of 1 1/4" into concrete or masonry at each location with a 2 1/2" min. from edge distance. For concrete (min. fc = 3000 psi) or masonry substrate (min fc = 2000 psi) (CMU shall adhere to ASTM C90).
3. Install corrosion resistant 1-#8 X 2" screws through each hinge into rough opening.
4. Install corrosion resistant 2-#8 X 2" screws through each strike plate into rough opening.
5. Host structure (wood buck, stud framing and opening) to be designed and anchored to properly transfer all loads to the structure. The host structure is the responsibility of the architect or engineer of record for the project of installation.

**General Notes:**

1. The product shown herein is designed, tested and manufactured to comply with the wind load criteria of the adopted International Building Code (IBC), the International Residential Code (IRC), the Florida Building Code (FBC) excluding HVHZ and the industry standard requirement for the stated conditions.
2. Buck, framing and masonry by others and is responsibility of architect or engineer of record.
3. All glazing shall conform to ASTM E1300.
4. At minimum, glazing shall be 3.0mm tempered - 14.1mm airspace - 3.0mm annealed - 2.3mm PVB Interlayer by Dupont - 3.0mm annealed insulating glass.

This schedule addresses only the fasteners required to anchor the window to achieve the rated design pressure up to the size limitations noted. It is not intended as a guide to the installation process and does not address the sealing consideration that may arise in different wall conditions. For the complete installation procedure, see the instructions packaged with the door or go to [www.jeld-wen.com](http://www.jeld-wen.com).

**DISCLAIMER:**

This drawing and its contents are confidential and are not to be reproduced or copied in whole or in part or used or disclosed to others except as authorized by JELD-WEN Inc.

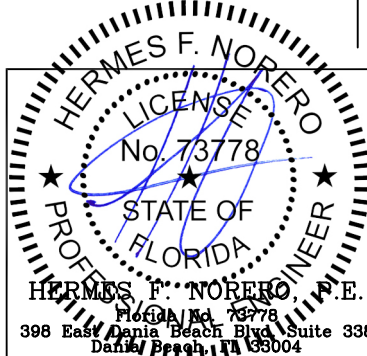

PROJECT ENGINEER: ---	DATE: 11/02/2017
DRAWN BY: D. Vezo	SCALE: NTS
CHECKED BY: J. Hawkins	TITLE: Architectural Fiberglass Impact Opaque 2 Panel Outswing Door
APPROVED BY: D. Vezo	
PART/PROJECT No.:	
D014773	
IDENTIFIER No. TEL 01681715	PLANT NAME AND LOCATION: ----



3737 Lakeport Blvd  
Klamath Falls, OR. 97601  
Phone: (800) 535-3936

CAD DWG. No.:	REV:	SHEET
---------------	------	-------

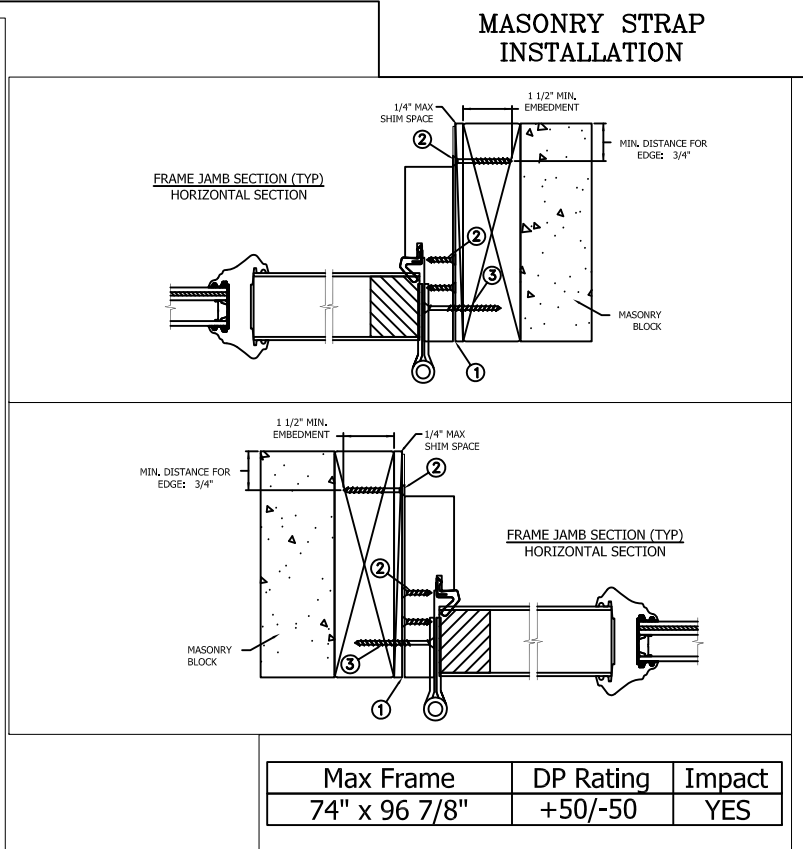
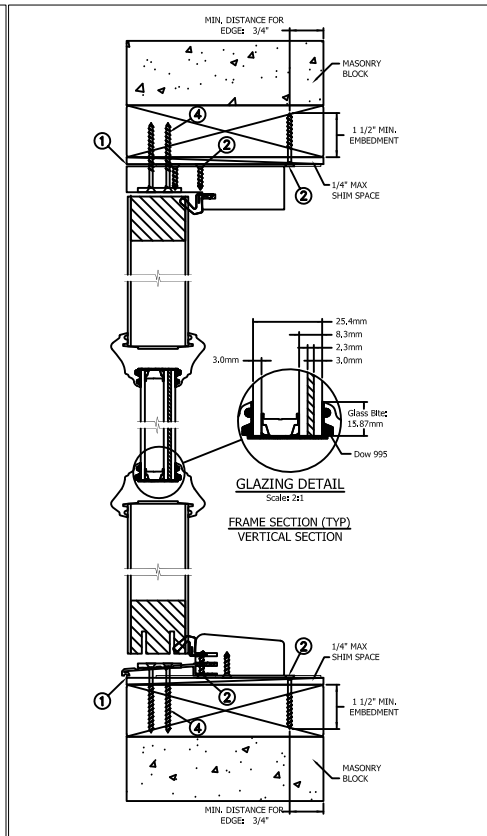
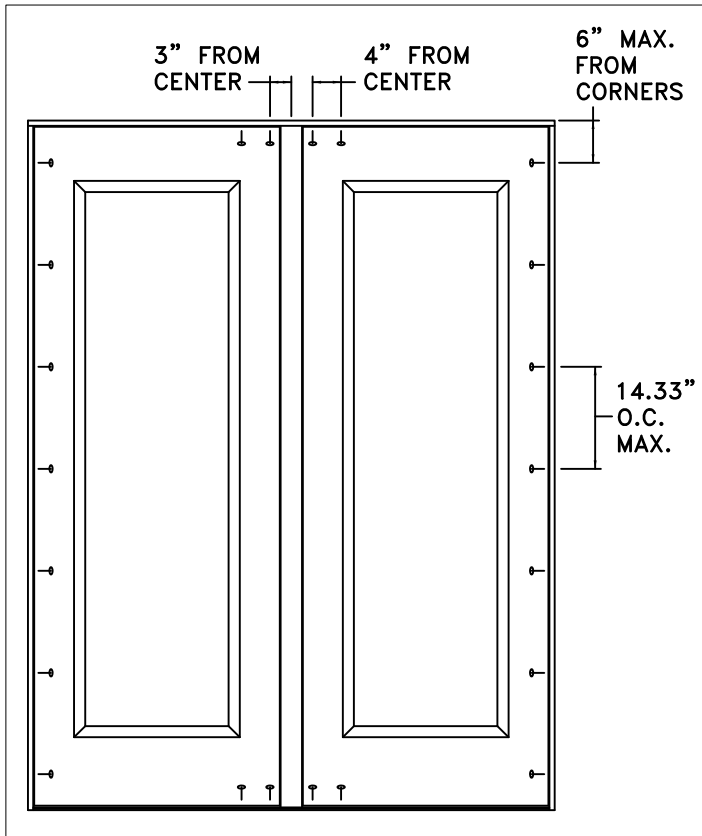

**Installed Fastener Schedule:**

1. Seal flange/frame to substrate.
2. Install masonry straps to wood frame using #8 corrosion resistant fasteners no more than 6" from each corner and 14.33" o.c. along the jambs and head. Bend straps around buck and secure with #8 fastener thru masonry strap into buck. Fasteners must be long enough to penetrate at least 1" into framing members.
3. Install corrosion resistant 1-#8 X 2" screws through each hinge into rough opening.
4. Install corrosion resistant 2-#8 X 2" screws through each strike plate into rough opening.
5. Host structure (wood buck, stud framing and opening) to be designed and anchored to properly transfer all loads to the structure. The host structure is the responsibility of the architect or engineer of record for the project of installation.

**General Notes:**

1. The product shown herein is designed, tested and manufactured to comply with the wind load criteria of the adopted International Building Code (IBC), the International Residential Code (IRC), the Florida Building Code (FBC) excluding HVHZ and the industry standard requirement for the stated conditions.
2. Buck, framing and masonry by others and is responsibility of architect or engineer of record.
3. All glazing shall conform to ASTM E1300.
4. At minimum, glazing shall be 3.0mm tempered - 14.1mm airspace - 3.0mm annealed - 2.3mm PVB Interlayer by Dupont - 3.0mm annealed insulating glass.

This schedule addresses only the fasteners required to anchor the window to achieve the rated design pressure up to the size limitations noted. It is not intended as a guide to the installation process and does not address the sealing consideration that may arise in different wall conditions. For the complete installation procedure, see the instructions packaged with the door or go to [www.jeld-wen.com](http://www.jeld-wen.com).

**DISCLAIMER:**

This drawing and its contents are confidential and are not to be reproduced or copied in whole or in part or used or disclosed to others except as authorized by JELD-WEN Inc.

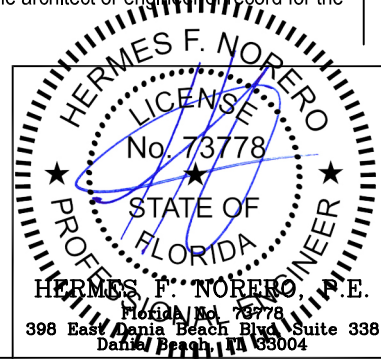

PROJECT ENGINEER: ---	DATE: 11/02/2017	<h1 style="margin: 0;">JELD-WEN</h1> <p style="margin: 0;">3737 Lakeport Blvd Klamath Falls, OR. 97601 Phone: (800) 535-3936</p>	
DRAWN BY: D. Vezo	SCALE: NTS		
CHECKED BY: J. Hawkins	<h2 style="margin: 0;">Architectural Fiberglass Impact Opaque 2 Panel Outswing Door</h2>		
APPROVED BY: D. Vezo			
PART/PROJECT No.:	<b>D014773</b>		
IDENTIFIER No. TEL 01681715			
PLANT NAME AND LOCATION: ----	CAD DWG. No.:	REV:	SHEET

3" FROM CENTER      4" FROM CENTER      6" MAX. FROM CORNERS

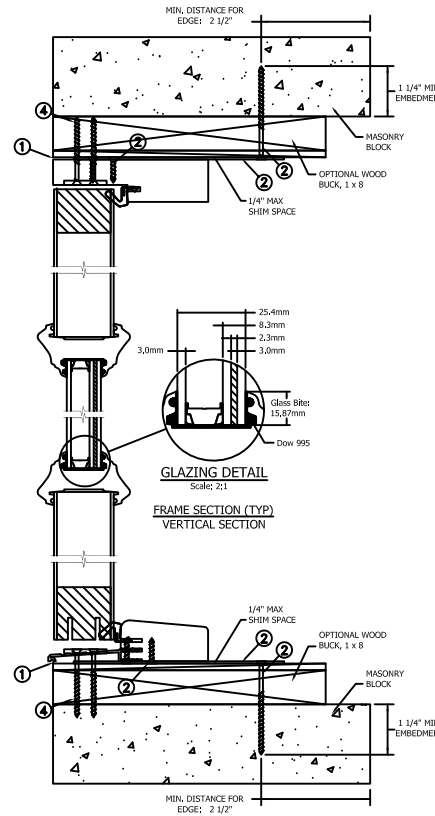
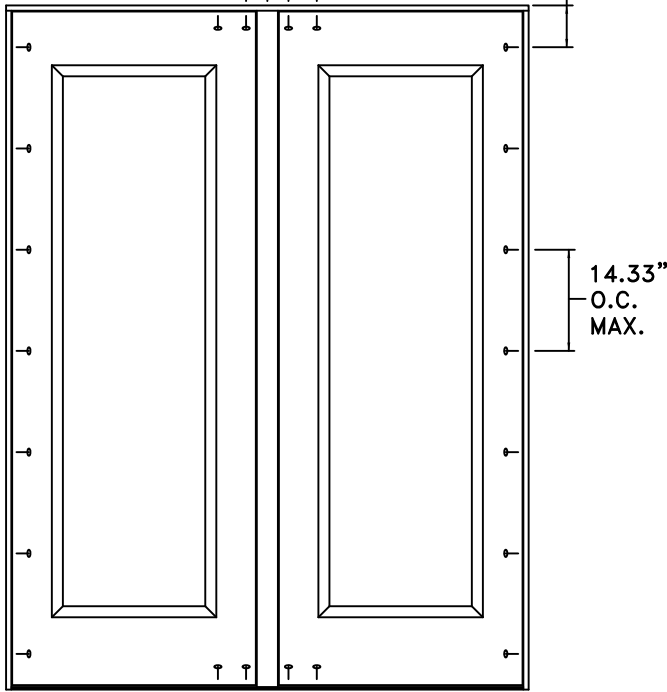

### MASONRY STRAP INSTALLATION

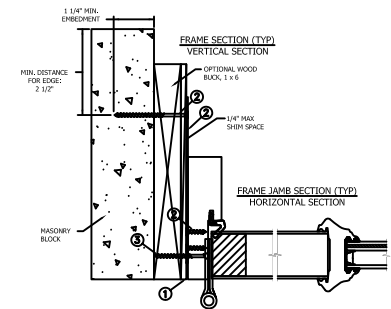
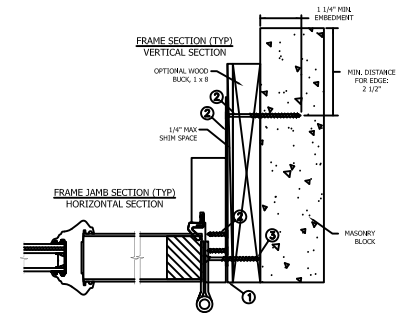

Max Frame	DP Rating	Impact
74" x 96 7/8"	+50/-50	YES

#### Installed Fastener Schedule:

1. Seal flange/frame to substrate.
2. Use 3/16" Tapcon or equivalent fasteners through strap with sufficient length to penetrate a minimum of 1 1/4" into concrete or masonry at each location with a 2 1/2" min. from edge distance. 2-#8 x 1/2" PH screws through the strap into frame. For concrete (min. fc = 3000 psi) or masonry substrate (min fc = 2000 psi) (CMU shall adhere to ASTM C90).
3. Install corrosion resistant 1-#8 X 2" screws through each hinge into rough opening.
4. Install corrosion resistant 2-#8 X 2" screws through each strike plate into rough opening.
5. Host structure (wood buck, stud framing and opening) to be designed and anchored to properly transfer all loads to the structure. The host structure is the responsibility of the architect or engineer of record for the project of installation.

#### General Notes:

1. The product shown herein is designed, tested and manufactured to comply with the wind load criteria of the adopted International Building Code (IBC), the International Residential Code (IRC), the Florida Building Code (FBC) excluding HVHZ and the industry standard requirement for the stated conditions.
2. Buck, framing and masonry by others and is responsibility of architect or engineer of record.
3. All glazing shall conform to ASTM E1300.
4. At minimum, glazing shall be 3.0mm tempered - 14.1mm airspace - 3.0mm annealed - 2.3mm PVB Interlayer by Dupont - 3.0mm annealed insulating glass.

This schedule addresses only the fasteners required to anchor the window to achieve the rated design pressure up to the size limitations noted. It is not intended as a guide to the installation process and does not address the sealing consideration that may arise in different wall conditions. For the complete installation procedure, see the instructions packaged with the door or go to [www.jeld-wen.com](http://www.jeld-wen.com).

#### DISCLAIMER:

This drawing and its contents are confidential and are not to be reproduced or copied in whole or in part or used or disclosed to others except as authorized by JELD-WEN Inc.

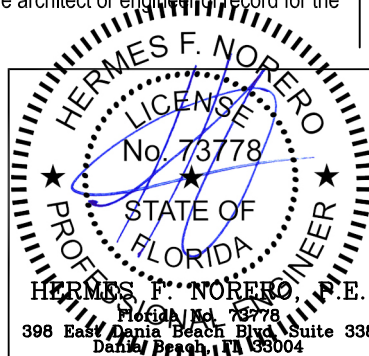

PROJECT ENGINEER: ---	DATE: 11/02/2017	<b>JELD-WEN</b>	3737 Lakeport Blvd Klamath Falls, OR. 97601 Phone: (800) 535-3936		
DRAWN BY: D. Vezo	SCALE: NTS				
CHECKED BY: J. Hawkins	TITLE: Architectural Fiberglass Impact Opaque 2 Panel Outswing Door				
APPROVED BY: D. Vezo					
PART/PROJECT No.:	D014773				
IDENTIFIER No. TEL 01681715	PLANT NAME AND LOCATION: ----	CAD DWG. No.:	REV:	SHEET	

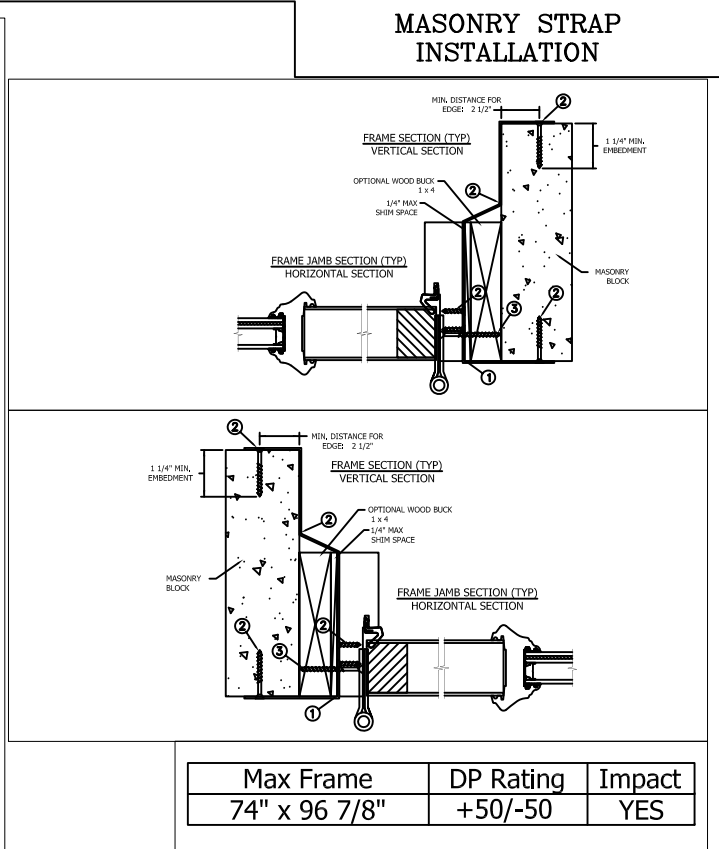
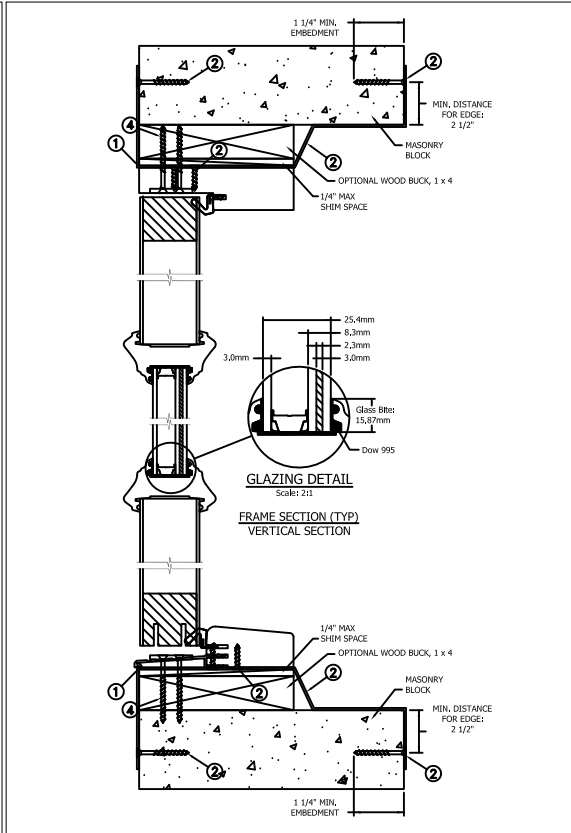
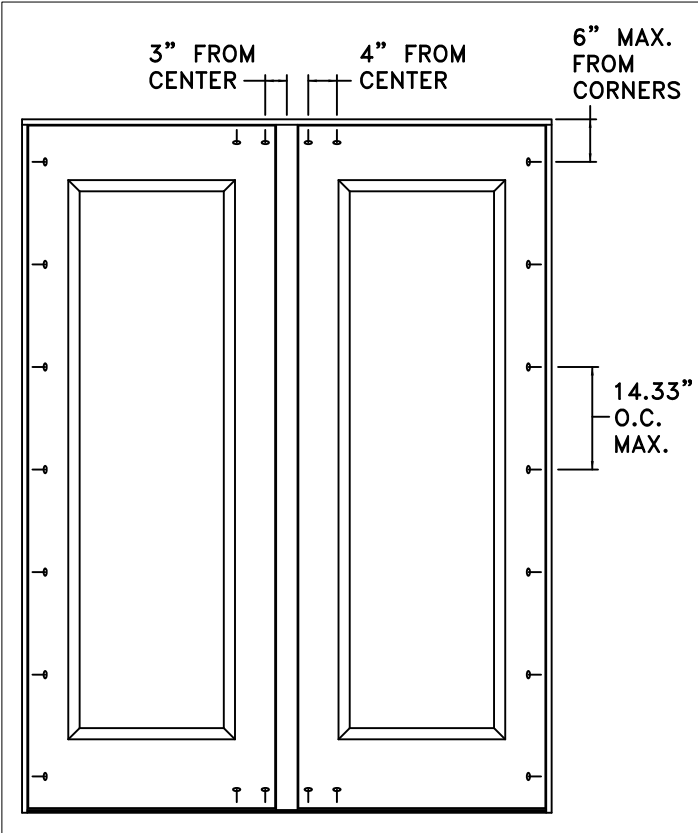

**Installed Fastener Schedule:**

1. Seal flange/frame to substrate.
2. Use 3/16" Tapcon or equivalent fasteners through the interior and exterior of the strap with sufficient length to penetrate a minimum of 1 1/4" into concrete or masonry at each location with a 2 1/2" min. from edge distance. 2-#8 x 1/2" PH screws through the strap into frame. For concrete (min. fc = 3000 psi) or masonry substrate (min fc = 2000 psi) (CMU shall adhere to ASTM C90).
3. Install corrosion resistant 1-#8 X 2" screws through each hinge into rough opening.
4. Install corrosion resistant 2-#8 X 2" screws through each strike plate into rough opening.
5. Host structure (wood buck, stud framing and opening) to be designed and anchored to properly transfer all loads to the structure. The host structure is the responsibility of the architect or engineer of record for the project of installation.

**General Notes:**

1. The product shown herein is designed, tested and manufactured to comply with the wind load criteria of the adopted International Building Code (IBC), the International Residential Code (IRC), the Florida Building Code (FBC) excluding HVHZ and the industry standard requirement for the stated conditions.
2. Buck, framing and masonry by others and is responsibility of architect or engineer of record.
3. All glazing shall conform to ASTM E1300.
4. At minimum, glazing shall be 3.0mm tempered - 14.1mm airspace - 3.0mm annealed - 2.3mm PVB Interlayer by Dupont - 3.0mm annealed insulating glass.

This schedule addresses only the fasteners required to anchor the window to achieve the rated design pressure up to the size limitations noted. It is not intended as a guide to the installation process and does not address the sealing consideration that may arise in different wall conditions. For the complete installation procedure, see the instructions packaged with the door or go to [www.jeld-wen.com](http://www.jeld-wen.com).

**DISCLAIMER:**

This drawing and its contents are confidential and are not to be reproduced or copied in whole or in part or used or disclosed to others except as authorized by JELD-WEN Inc.

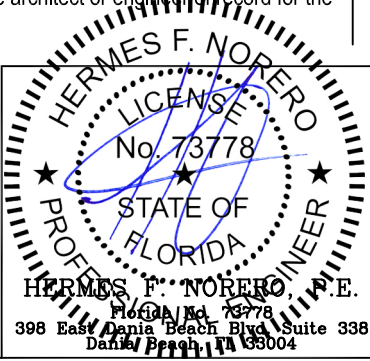

PROJECT ENGINEER: ---	DATE: 11/02/2017	<h1 style="margin: 0;">JELD-WEN</h1>	3737 Lakeport Blvd Klamath Falls, OR. 97601 Phone: (800) 535-3936		
DRAWN BY: D. Vezo	SCALE: NTS				
CHECKED BY: J. Hawkins	<h2 style="margin: 0;">Architectural Fiberglass Impact Opaque 2 Panel Outswing Door</h2>				
APPROVED BY: D. Vezo					
PART/PROJECT No.:					
<b>D014773</b>					
IDENTIFIER No. TEL 01681715	PLANT NAME AND LOCATION: ----	CAD DWG. No.:	REV:	SHEET	

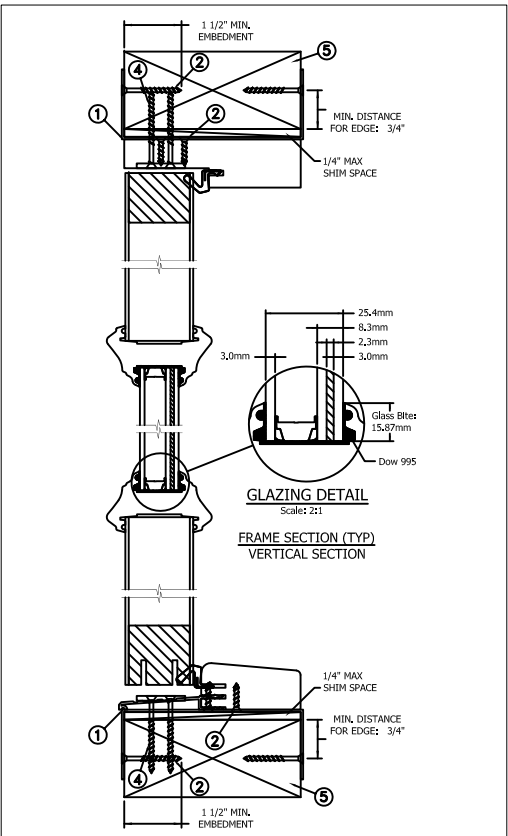
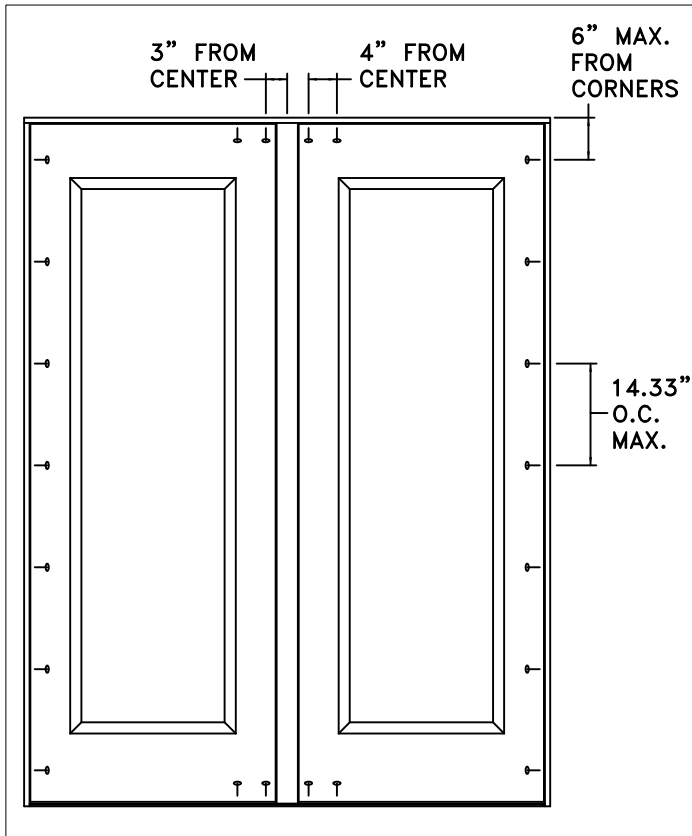

### MASONRY STRAP INSTALLATION

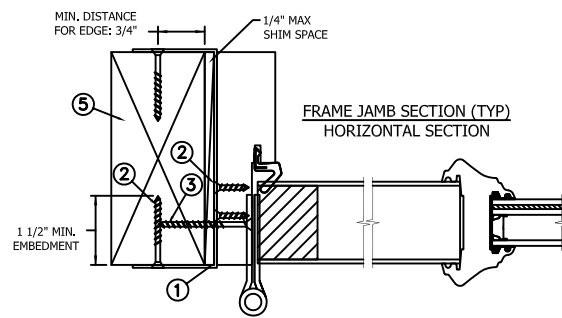
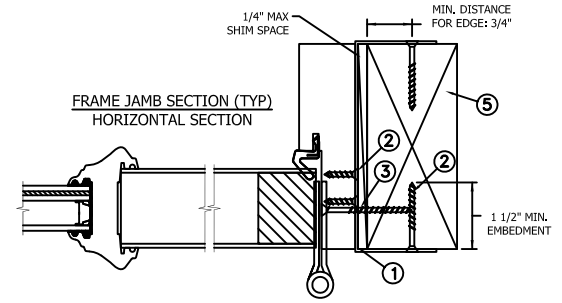

Max Frame 74" x 96 7/8"	DP Rating +50/-50	Impact YES
----------------------------	----------------------	---------------

#### Installed Fastener Schedule:

1. Seal flange/frame to substrate.
2. Install masonry straps to wood frame using #8 corrosion resistant fasteners no more than 6" from each corner and 14.33" o.c. along the jambs and head. Bend straps around buck to the interior and exterior, and secure with #8 fastener thru masonry strap into buck. Fasteners must be long enough to penetrate at least 1 1/2" into framing members. Minimum specific gravity = (Min. S.G. = 0.42).
3. Install corrosion resistant 1-#8 X 2" screws through each hinge into rough opening.
4. Install corrosion resistant 2-#8 X 2" screws through each strike plate into rough opening.
5. Host structure (wood buck, stud framing and opening) to be designed and anchored to properly transfer all loads to the structure. The host structure is the responsibility of the architect or engineer of record for the project of installation.

#### General Notes:

1. The product shown herein is designed, tested and manufactured to comply with the wind load criteria of the adopted International Building Code (IBC), the International Residential Code (IRC), the Florida Building Code (FBC) excluding HVHZ and the industry standard requirement for the stated conditions.
2. Buck, framing and masonry by others and is responsibility of architect or engineer of record.
3. All glazing shall conform to ASTM E1300.
4. At minimum, glazing shall be 3.0mm tempered - 14.1mm airspace - 3.0mm annealed - 2.3mm PVB Interlayer by Dupont - 3.0mm annealed insulating glass.

This schedule addresses only the fasteners required to anchor the window to achieve the rated design pressure up to the size limitations noted. It is not intended as a guide to the installation process and does not address the sealing consideration that may arise in different wall conditions. For the complete installation procedure, see the instructions packaged with the door or go to [www.jeld-wen.com](http://www.jeld-wen.com).

#### DISCLAIMER:

This drawing and its contents are confidential and are not to be reproduced or copied in whole or in part or used or disclosed to others except as authorized by JELD-WEN Inc.

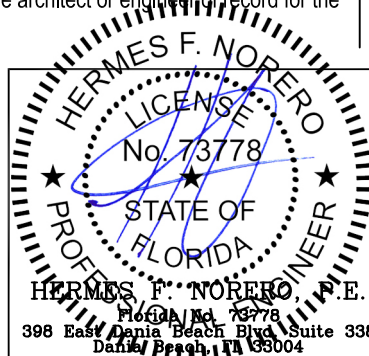

PROJECT ENGINEER: ---	DATE: 11/02/2017	<b>JELD-WEN</b>	3737 Lakeport Blvd Klamath Falls, OR. 97601 Phone: (800) 535-3936	
DRAWN BY: D. Vezo	SCALE: NTS			
CHECKED BY: J. Hawkins	TITLE: Architectural Fiberglass Impact Opaque 2 Panel Outswing Door			
APPROVED BY: D. Vezo				
PART/PROJECT No.: D014773				
IDENTIFIER No. TEL 01681715	PLANT NAME AND LOCATION: ----	CAD DWG. No.:	REV:	SHEET